

Technický list **láhev | DL-L 50**
**základní data**

nominální objem	500 ml
průměr	Ø 66,50
výška	211 mm
hmotnost	41 g
tolerance hmotnosti	± 2 g
typ hrdla	28/410
barva	bílá

**logistika**

karton	102 ks/karton
paleta jednoduchá   80 x 120	1715 ks/paleta

**materiál**

typ	HDPE
určeno	FOOD   NON-FOOD

**uzávěr**
**šroubovací uzávěr  
28/410**

hrdlo	28/410
barva	bílá
hmotnost	2,5 g ± 1 g tolerance
materiál	PP
určeno	FOOD   NON-FOOD

**uzávěr flip top  
28/410**



hrdlo	28/410
barva	bílá
hmotnost	5 g ± 1 g tolerance
materiál	PP
určeno	FOOD   NON-FOOD

**pumpa  
28/410**

hrdlo	28/410
barva	bílá
hmotnost	xx g ± xx g tolerance
materiál	PP
určeno	FOOD   NON-FOOD

**produktová řada - DL-L**

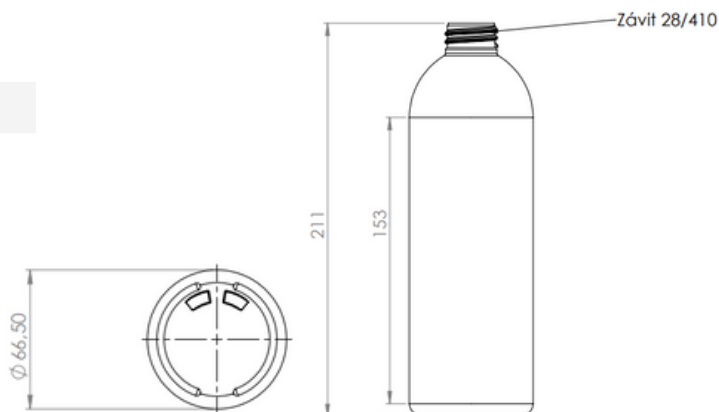
DL-L 25	<b>DL-L 50</b>	DL-L 100
250 ml	<b>500 ml</b>	1000 ml



\*pouze při odběru 5 a více palet

date : 09.2023 ver. 01

 Roveň 46, 463 48 Všelibice  
 DIČ: CZ25022695  
 +420 485 148 829  
 drevoplast@drevoplast.com  
 www.drevoplast.com
